

Signal	GPIO J1	Signal	Port	GPIO J1
GND	2	X0D31 ¹	P4F3	1
GND	4	X0D30 ²	P4F2	3
GND	6	X0D29 ³	P4F1	5
GND	8	X0D28 ⁴	P4F0	7
GND	10	X0D33	P4E3	9
GND	12	X0D32	P4E2	11
GND	14	X0D27 ⁵	P4E1	13
GND	16	X0D26 ⁶	P4E0	15
#SPI_IRQ: X0D35 P1L 17				
MOSI SPI_MO (SPI_DI): X0D34 P1K 19				
CLK SPI_CLK: X0D25 P1J 21				
MISO SPI_MI (SPI_DO): X0D24 P1I 23				
GND	26	X0D19	P4D3	25
GND	28	X0D18	P4D2	27
#LED1: X0D17 P4D1 29				
#LED0: X0D16 P4D0 31				
GND	34	X0D23	P1H	33
GND	36	X0D22	P1G	35
GND	38	X0D13 ⁷	P1F	37
GND	40	X0D12 ⁸	P1E	39
GND	42	X0D21	P4C3	41
GND	44	X0D20	P4C2	43
#SPI_EN (#PWR_EN): X0D15 P4C1 45				
#SPI_CS: X0D14 P4C0 47				
GND	50	X0D09	P4A3	49
GND	52	X0D08	P4A2	51
GND	54	X0D03	P4A1	53
GND	56	X0D02	P4A0	55
GND	58	X0D39	P1P	57
GND	60	X0D38	P1O	59
GND	62	X0D37	P1N	61
GND	64	X0D36	P1M	63

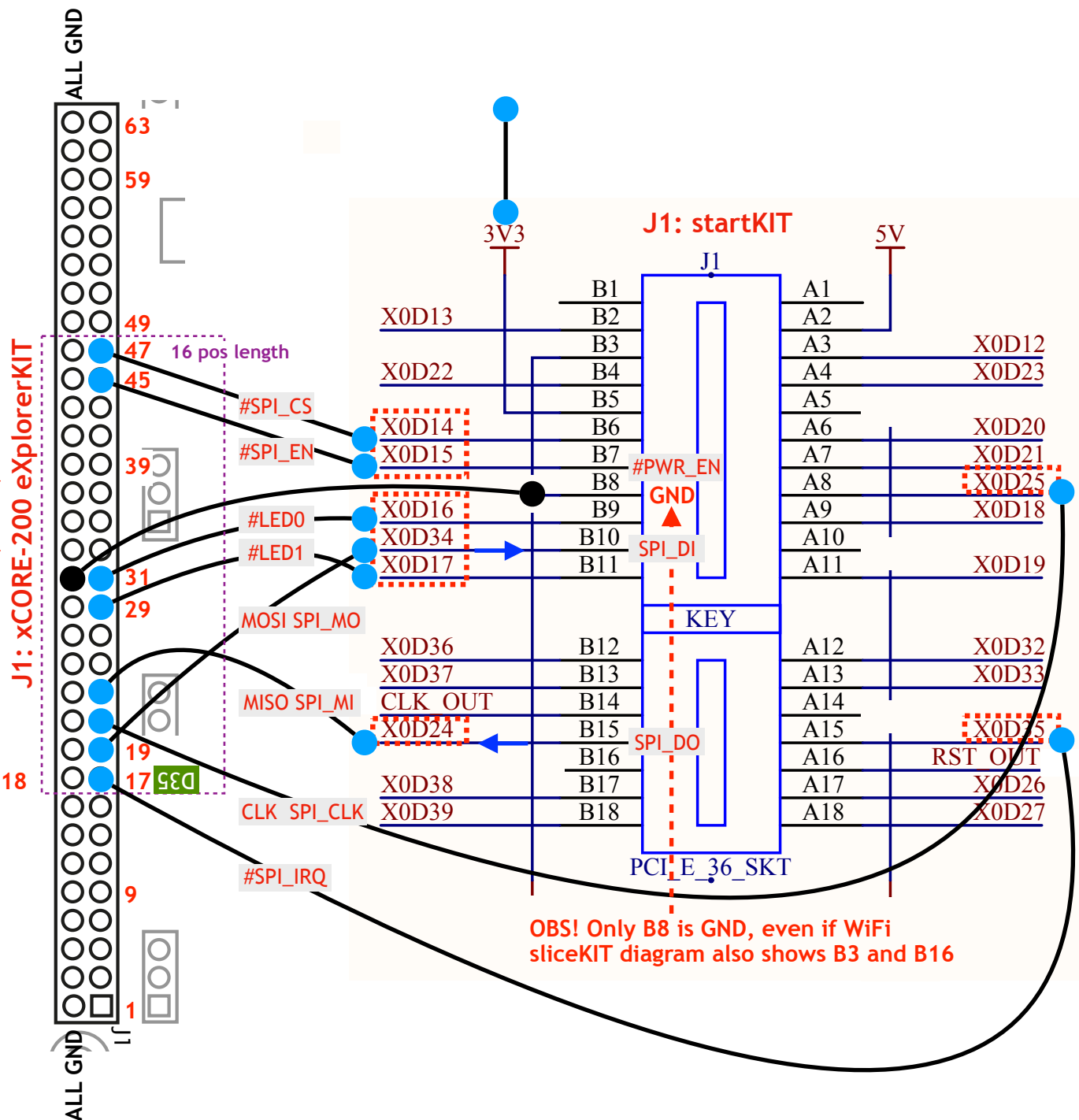

Drawing 101: J1 on startKIT and WiFi sliceCard breakout board for J1 on xCORE-200 eXplorerKIT